



The Trillium

Volume 52 Issue 2

April 2024



Inside This Issue...

Events Calendar	2	Sunshine Report	23
President's Message	4	My Tank Overfloweth	24
Special Appeal for Tornado Relief	5	Community Services Update	26
Region 2 President's Message	6		
New Members	8		
Western Shakedown Update	9		
Eastern Shakedown Update	10		
Spring Rally Update	11		
Fall Rendezvous Update	14		
A Taste of New York Rally	15		
Grapes & Grains Caravan & Rally	16		
A Salute to One of Our Own	17		
Editorial	20		
Caravan Corner	21		

Events Calendar

May 2 - 5	Region 2 Rally "Pursue Your Adventure" Centre County Grange Encampment & Fair, Pennsylvania	Registration open now
May 9 - 13	Eastern Ontario Shakedown Richmond Fair Ground	Lynn & Rob D. Roger & Janice J. Larry & June D.
May 10 - 13	Western Ontario Shakedown Seaforth Agricultural Grounds	Tony S. Neil & Nancy M.
May 16 - 21	Flamingo Fling Spring Rally & AGM Blyth Fairgrounds, ON	Registration open now Kathy B. & Gordon D. Donna C. & Allan S. Pat & Murray L. John W. & Lois W.
Aug. 1 - 5	A Taste of New York Rally Sampson State Park, NY	Registration open now
Aug. 20 - 29	Grapes & Grains Caravan Wapakoneta, OH to KOA, Niagara Falls, ON	Registration open now
Aug. 29 - Sep. 2	Grapes & Grains Intra-Club Sip Rally KOA, Niagara Falls, ON	Registration open now
Sep. 5 - 9	Fall Rally & AGM Can-Am RV, London	Andy T. Volunteers needed! Boondocking opportunity
Sep. 5 - 8	2024 Pennsylvania Rally Emlenton Pennsylvania	If you're in the Pennsylvania area... Registration open now

Sep. 19 - 23	Fall Rendezvous #1 Western Ontario Summer House Park	Jim & Ena F. Volunteers needed!
Date TBA	Fall Rendezvous #2 Eastern Ontario Lindsay Fairgrounds	Bill & Julie R. Mentors needed!
Oct. 5 - 10	67th International Rally Sedalia Missouri	Just a short hop from Ontario Registration open now
Aug. 23 - 28, 2025	68th International Rally York Pennsylvania	An even shorter hop from Ontario! Registration TBA

President's Message

Melanie C.

Welcome Spring! It's exciting to think that in a few short weeks we will be dusting off our rigs and loading up for our first camping trip. We are looking forward to the Shakedown in Seaforth. It has great shops, a crazy barber and peaceful campsites.

The Spring Rally in Blyth promises to be a great opportunity to catch up with friends, check out the countryside and pull out your flamingos for all to admire. There may be prizes for flamingo displays!

I hope that those of you enjoying the warmer weather in the sunny south will all return home to Ontario safely, ready for our fabulous Canadian summers!

See you all very soon!

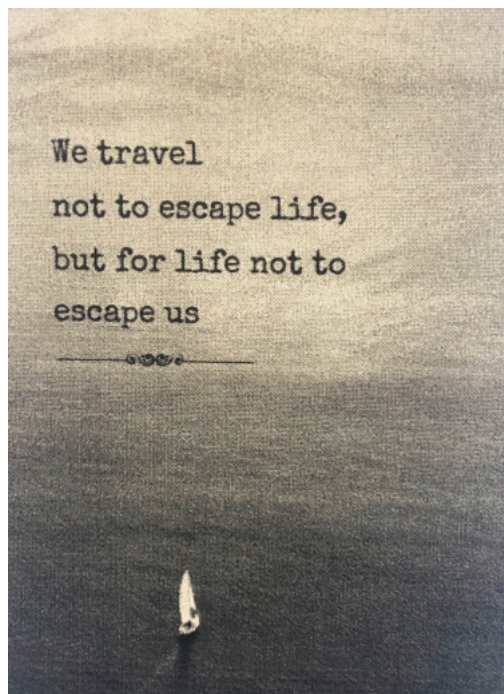

Special Appeal for Tornado Relief

Gary R. - Region 2 President

[Editor's note: The following appeal was forwarded to me by Melanie C. It has been edited for inclusion in the newsletter.]

I am reaching out to you to help those affected by the tornado in Logan County, Ohio. As you may know, most of the members of your Executive Council and International Board of Trustees experienced the tornado alongside the residents of Logan County, especially Lakeview and Russells Point.

To help with the relief efforts, the Logan County United Way has been set up to receive and distribute donations. Since it is a 501C3 organization, all US donations will be tax deductible. The link for the Logan County United Way is below. If you choose to donate, please indicate you are with Airstream Club International.

This was an EF2 tornado with winds of 120 mph, and none of us will forget it. All of the workers for Airstream, Inc. were affected. It's time to unite as a community to help our fellow Airstream workers and all those who need to rebuild!

Thank you in advance for your generosity to this cause.

I've included some photos from the home next to the AirBnB where some of our Region Presidents were staying and rode out this tornado.

Gratefully,

Gary R.

<http://uwlogan.org/>

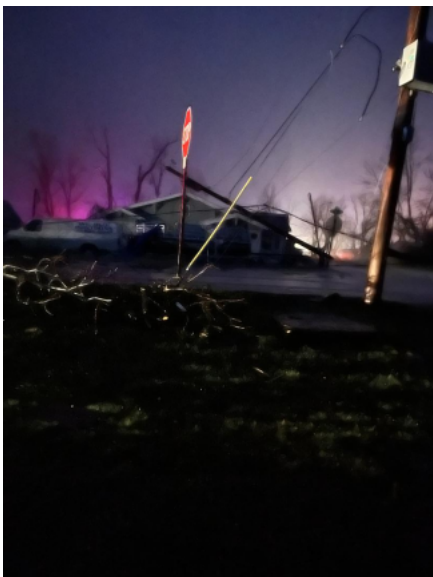

Region 2 President's Message

Gary R.



Spring is in the Air

For me April means one thing. Some of you may think of moving the clocks forward, as in spring ahead. For me the truck and trailer come out of winter storage.

There is still time and space to sign up for the [Region 2 Rally in Centre PA.](#)

In March, we had our Mid-Winter IBT Strategy meeting in Jackson Center.

During the meeting we discussed several Club concerns:

- Internal Communications
- External Communications
- Welcome and Retention of members
- Infrastructure (building and software)
- Training of officers (at all levels)
- Financial Literacy and Sustainability -- For further information, refer to the April 2024 Blue Beret Blog.

We were lucky at the Mid-Winter IBT as Suzanne and I left Jackson Center approximately 1.5 hrs. before an EF 2 Tornado hit Logan County. For reference, an EF 2 Tornado has winds ranging between 113-157 mph. Logan County received some serious damage to the area.

In March, I sent out a News Flash about the June election. Below is a map of the members in North America. As you can see, there is a very high density of members in Region 2. As I pointed out in the News Flash, only 311 people out of 965 from Region 2 voted in the last election. Region 2 has 13 clubs so that means on average 24 members from each club voted. Jackson Center will have a Campfire meeting where the topic for the vote will be centerstage as well as sending out multiple emails on the topic. To make sure people without email access are notified, I will be contacting the local Club Presidents, and a snail mail notification will be sent to members without an email address. Jackson Center will send out a paper ballot if one is requested.

We have been working hard with 3rd party vendors to get benefits for our ACI members. I have attached a document listing these benefits along with links to their websites.

See you down the road.

Gary

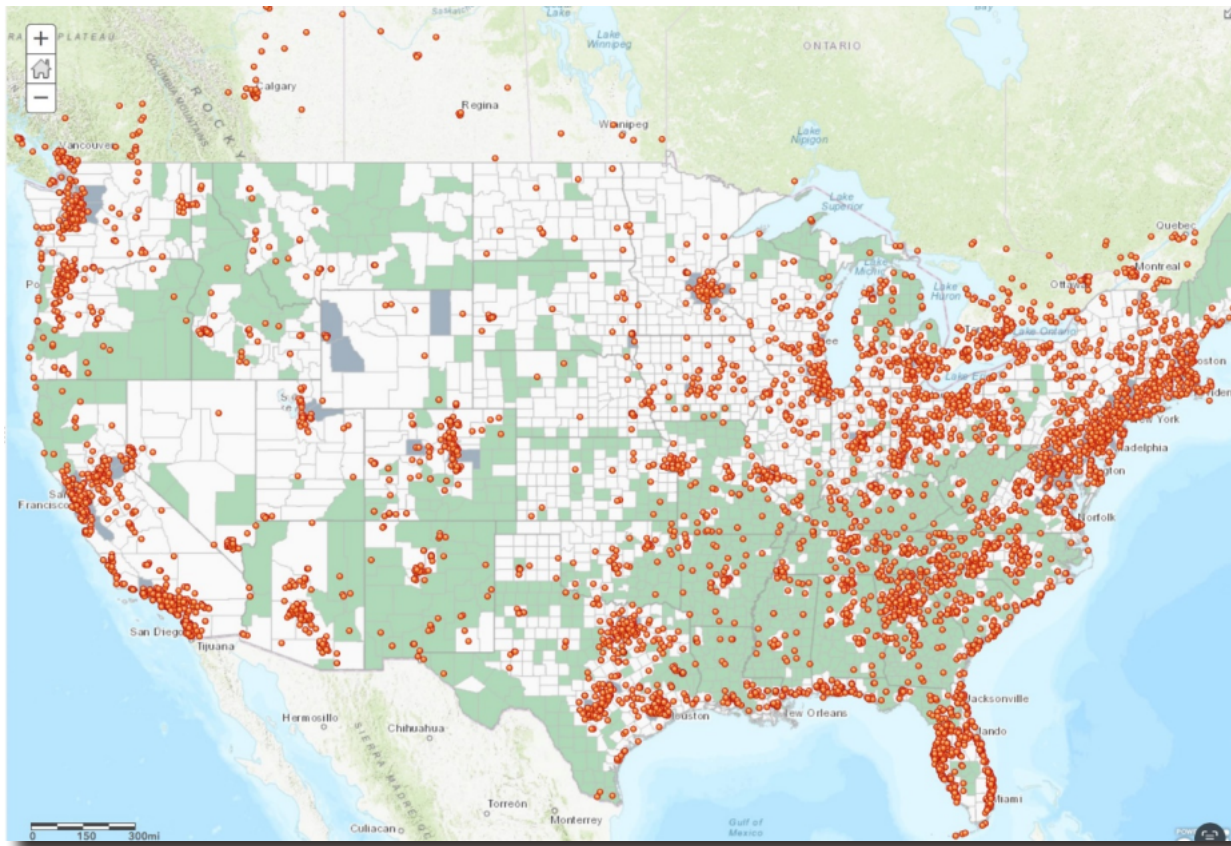

New Members

Please welcome our newest OCAC members.

Elida & Bernard S.
2021 Flying Cloud 30'

Adin & Wendy S.
2017 Flying Cloud 25'

Guy & Sue P.
2015 Flying Cloud 25'

Janice & Mark C.
2022 Caravel 22'

Walter B. & Nina M.
2023 Flying Cloud 25'

Bill & Suzanne J.
2016 Classic 30'

New members are reminded to send in headshots (together with partner if applicable) to the [newsletter editor](#) or Kathy B.



Thanks Can-Am for
all your support!

Western Ontario Shakedown Update

Neil & Nancy M.

The 2024 Western Ontario Shakedown will be held in Seaforth, at the Seaforth Agricultural Fairgrounds. All sites have water and 30A service and a dump station is available. There are washrooms available for use, but NO showers. The grounds are reserved from Friday, May 10 until Sunday, May 12. The cost is \$45 per night and longer stays may be possible. The fair has asked we pay in CASH!

There will be mid-morning coffee gatherings, the option to eat out at a local restaurant, possibly an evening at the local Legion, Happy Hours every day and campfires! There will be lots of time to socialize, be a tourist and of course to shakedown your rig!

Seaforth is a town of 2700 in South Western ON, a 30 minute drive to Goderich and Bayfield on Lake Huron to the west, and the same distance to Stratford in the east. There are several well regarded provincial parks in the area as well.

The Spring Rally, only about 20 minutes down the road in Blyth, has early check-in May 16.

If interested please contact:

Neil/Nancy M.

OR

John/Joan G.



Seaforth Agricultural Fairgrounds. Still no Airstreams

Eastern Ontario Shakedown Update

Lynn & Rob D.

We are pleased to announce that our 2024 Eastern Ontario Shakedown will take place from Thursday May 9 through Monday May 13, 2024, at the Richmond Fair Ground. This is the weekend before the Victoria Day long weekend and the Spring Rally in Blyth.

As usual we will have our Thursday trip to The Glen Restaurant at 5:00 p.m. for early arrivals, Friday snack at 7:00 p.m.; Pot-Luck meal on Saturday at 5:00 p.m., and a Sunday breakfast, cooked and served by the hosts and volunteers at 8:30. The hall (Heated, Dry and Bug-Free as needed) will be available to us all weekend for Happy Hours, games, deep technical discussions, and general merriment.

The camping fee for the event will be \$50 per night. The fee for the hall and food will be split evenly amongst the participants. Based on the expected number of participants it will be in the order of \$30. Payment will be collected at the event. The fairground has a mix of 15 and 30 A hydro, daisy-chained water, a washroom (no shower) and a dump station.

If you plan to attend, please email, or call Lynn & Rob with your arrival & departure dates and if you are interested in the Thursday trip to The Glen.

If you have any questions, please get in touch with Lynn & Rob D.

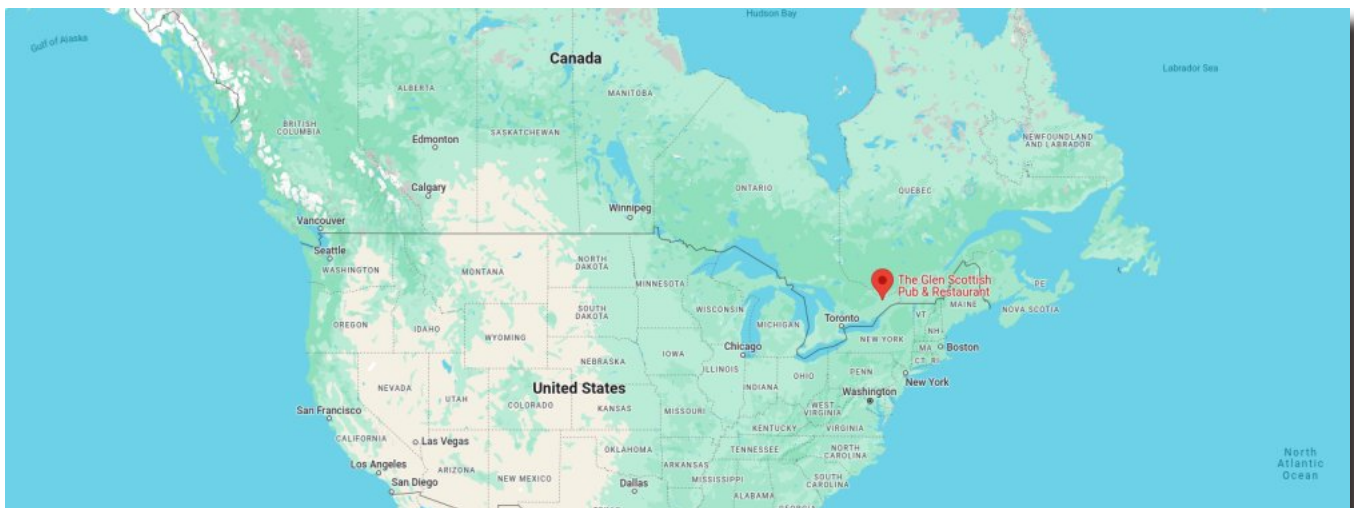

Spring Rally Update

Kathy B. & Pat L.

Get Your Flamingo On at the Flamingo Fling Spring Rally in Blyth, ON

It's getting closer! Your host team is looking forward to seeing you at the "Flamingo Fling" in Blyth. Here's your chance to wear those flamingo-logoed items hidden away in your closets and drawers! And of course, bring any other "flamingo bling" you want to show off!

We have the Blyth Campground for a total of 5 nights starting Thursday, May 16. Nightly camping fees are \$50.85. When you register at <https://airstreamclub.org/2024-spring-rally>, indicate what nights you plan to stay and the camping fee will be calculated automatically for you. Campsites will have electrical (at least 15 amps) and water hook-ups. Showers and toilets are located close to where we'll be camping and there's a dump station on site.



While we have the campground reserved from Thursday to Tuesday, the actual rally starts on Friday and ends on Monday. To be fair to everyone, the camping fee will be kept separate from the rally fee. The rally fee will cover the costs of:

- Breakfast on Saturday, Sunday and Monday of fruit and juices, cereals, and assorted baked goods and spreads, as well as the all-essential coffee and tea
- Refreshments Friday, Saturday and Sunday evening
- Common costs such as table coverings, dish detergent, printing and other miscellaneous items
- Saturday evening's entertainment. We've hired a DJ so bring your dancing shoes!

Saturday night's dinner is being catered by Pineridge BBQ out of Hensall. That cost is separate and you can select it as an option on the registration form. On Saturday afternoon prior to dinner, we plan to have "Hassle Tassel" – that's like a happy hour where you'll be invited to a small group "mix and mingle" hosted by one of our members at their camp site. You'll bring your chair, a snack to share and your beverage of choice. Keep your fingers crossed that Ma Nature cooperates!

For Sunday dinner, we'll have a pot luck dinner. Then, afterwards, we'll play some games and award prizes! (Spoiler alert – the prizes are really cute!)



See below for information about the golf game and opportunities to hike / bike the G2G Rail Trail. There'll also be a general membership meeting and a flea market. If you have something you want to move along to another owner, bring it along and put a price tag on it.

We're still working out some of the details. We'll send those out by email at the beginning of May, along with the program for the weekend. Watch for it!

Your host team:

- Kathy B. & Gordon D.
- Donna C. & Allan S.
- Pat & Murray L.
- Lois W. & John W.

Golf!

Team Kim & Jeannie E. invite you to join them on Saturday May,18, 2024 for a fun morning of golf at Woodlands Links Golf Course. The course is located at 37858 Huron Rd, Clinton – less than a 20-minute drive from the rally. In addition to being an Audubon and championship links course, its Club House is a former post and beam bank barn dating back to the 1840s.

There's room for 16 golfers over 4 tee times with the first tee off at 9 am. The cost for 18 holes – \$65 including cart and HST – is payable at the pro shop on arrival.

And what's golf without a little friendly competition? The competition includes:

- Longest drive - women's and men's
- Three closest to the pin, and a
- Putting challenge!

Contact Kim E. to reserve your spot.

Go for a hike!

Walkers, hikers, runners, cyclists - experience the G2G trail while in Blyth. Adjacent to the campground, the former rail route is about 28 km to Goderich and 104 km to Guelph. Their website, <https://g2grailtrail.com>, includes history and a detailed map to help you plan your adventures.

Contact Pat L. if you are interested in a group walk/hike 9 AM daily, weather allowing. Max 6-foot leashed (well mannered) dogs welcome.



Fall Rendezvous Update

Jim F.

September 19th - 23rd, 2024

We were called on last year to host a Rendezvous again this year at **Summer House Park** in Tobermory. The timing of Melanie's phone call couldn't have come at a better time; we were already at the Park and just needed to walk to the office and speak to them about scheduling another Airstream get together. They are quite happy to have us coming back.

Your host team of Jim & Ena F., Dwayne & Margaret R., Mark H. and Lynn E. are working on a schedule of events that will provide more opportunities for us to meet as a group. The rec. hall will be available for our use for meet and greet on Friday night and throughout the weekend. A schedule of events will follow, closer to the date.

Currently we are planning on a Pot-Luck dinner for Saturday night and a presentation on solar electric by David Elliott of GWN Marketing. As we are not planning on holding any breakfast gatherings we will only need volunteers to set up the hall for the pot-luck dinner and the presentation, and there won't be any additional fee to attend. There will be plenty of time for relaxation, socializing and enjoying all the Bruce Peninsula has to offer.

If you plan to attend, contact the park directly and make your reservation. Call them at 1-800-265-5557 and look up their website; summerhousepark.ca. Call early to avoid disappointment. This is a very popular destination and books to capacity at this time of year, especially on the weekends. Be sure to tell them you are with the Airstream Club. You'll find the park map of great assistance in choosing a site.

Looking forward to seeing you at Summer House Park.

Your host team.



A Taste of New York Rally

Gary R.



Tired of looking at your trailer in storage or the driveway?

If you attended last year's Sampson Rally, we hope you have fond memories. This year the theme is 'A Taste of New York'. The New York Finger Lakes Airstream Club along with the Hudson-Mohawk and Metropolitan New York Airstream Clubs have partnered together to add to those fond Airstream rally memories or to create new ones. We plan to showcase the taste of New York. On Friday, we plan to have tastings under the tent. The tastings will include wines and craft beers from the region. Each trailer will be provided with a Charcuterie Board box (enough for 2 people) and a bag of decadent popcorn, both provided by local vendors.

Last year, the event started with check in on Thursday and check out on Monday morning. This extended time was a real hit with the Canadians last year because they have a long weekend.

So, add your trailer to the August 1-5 shindig. As in the past, we have sites already reserved at Sampson State Park for the event (limited now to 97 sites), a larger meeting tent, and a live band. Cost information and registration using the JotForm is below.

<https://form.jotform.com/240374986998177>

Grapes & Grains Caravan & Rally

Grapes & Grains organizers

The long awaited CANADA CARAVAN: Grapes & Grains Intra-Club's Sipping Across Canada is now ready to accept reservations.

On August 20th, the Caravan begins at Wapakoneta, Ohio for two nights, which gives us time to explore Jackson Center, home of the Airstream Factories and the Airstream Heritage Museum. Then we head into Canada, crossing at Windsor, Ontario. Make sure your passports are up to date! Then we stay in Amherstburg, Ontario so we can visit J.P Wisers, home of Hiram Walker Whiskey and another distillery. Next we travel to Turkey Point, Ontario for visits to local wineries. Finally, we end up at Niagara Falls, Ontario, home to the 7th Natural Wonder of the World. Here we will take an all day guided bus tour of some of the wineries of the region. Next up is a bus pass which will take you anywhere in downtown Niagara Falls, from the Maid of the Mist boat ride to the Skylon Tower and many other attractions downtown. This caravan ends on Thursday August 29.



Click this [link](#) for additional information, agenda, and to register for this CANADA CARAVAN.

But WAIT, There's MORE.

The Grapes & Grains Intra-Club Sip of Niagara Falls RALLY, Ontario Canada starts on the same day, August 29, that the Caravan ends! Think of spending the 4 night Labor Day weekend in a wonderful KOA Holiday Campground, without moving your Airstream! Attending a different wine bus tour and two more full days to explore Niagara Falls. This rally ends on Monday, September, 2nd.

Click this [link](#) for additional information, agenda, and to register for the CANADA RALLY.

These are two separate events so you can go on the Caravan and the Rally or you can go on just one or the other.

We look forward to seeing many of you there!

A Salute to One of Our Own

Neil & Nancy M.

Kerry and Betty M. have been ON members since 2004. During these 20 years Kerry has been involved in many leadership positions. He was President of the Unit in 2010, Quartermaster for many years and a member of many committees including Constitution and Bylaws and our inexhaustible Caravan Chair for both Ontario and Region 2. He's led approximately 19 caravans including several to WBCCI Internationals throughout the US. His caravans were known for their laid back, relaxed atmospheres with just enough organized events, pancake breakfasts, Happy Hours, campfires and surprise pizza dinners! We have fond memories of those caravans where we travelled to destinations and experienced adventures we might not otherwise have had.



Caravanner Comments

Kerry and Betty have gone above and beyond for our amazing Airstream Club , always pleasant and helpful in whatever their roles, fantastic Caravan leaders, great President and First Lady, and Kerry always did an amazing job as Quartermaster, much thanks to an amazing couple. — John and Evie F.

Kerry and Betty M. will be leading a caravan for the last time this fall, their "Meandering the Maritimes" trip. The caravans that he has lead, both the formally organized ones and the "let's drive to International" ones are legendary for their organization without regimentation, and overall fun. We have lost count, and Kerry probably has too, of every trip that they have organized. We were fortunate enough to co-lead the first Circle Tour of Superior caravan in 2013 and were witness to the fact that the smooth running of the caravan is a result of lots of hard preparation. We are very fortunate to have had Kerry and Betty devote the required effort to make all their caravans such a success. The best way for our club members to say thank-you would be to have someone step forward to carry on the work that Kerry and Betty have done. — Rob and Lynn D.

Kerry and Betty have been the mainstay for many years of so many aspects in our Club and particularly organizing so many wonderful caravans all over North America. They were superb leaders, taking so many of us to see places we would not have seen on our own. Nothing seemed to faze him and they were both so welcoming and helpful to everyone. And we all had such fun when we went on one of their caravans that we wanted to know when their next caravan was. We have life long memories due to their dedication.

— Don and Kathy M.

Being newish Airstreamers back in 2016, we decided to go way outside our comfort zone and join the NWT/Yukon caravan. Never being on a long caravan, we were not sure it was for us. Kerry and Betty made us feel very comfortable with their excellent leadership, friendliness, and preparation. Not only did they make us feel comfortable traveling with new people, we have very fond memories of this group and this experience. We so want to go back to the north! Since then we have traveled with K&B to the Maritimes (twice), and to New York City. We are so grateful for being able to travel as part of their caravans! — John and Joan G.



Camped on the way to Salem International 2018

Kerry and Betty M. have been leading caravans since 2007 when they routed Ontario participants to the International Rally in Perry, Georgia. Others have been around Lake Superior, as far north as the Northwest Territories and Yukon, as far west as Salem, Oregon, and several to eastern Canada and the US. Last summer, they led a Region 2 group in their “Meandering the Maritimes Caravan”. Having been on a number of caravans that Kerry and Betty have led, I can attest to how enjoyable they are—extremely well-planned, quite laid back and yet with lots of adventures and great, great times! — Kathy B.

Adventure is where you find it, any place, every place, except at home in the rocking chair. — Wally Byam

Thank you Kerry and Betty for the fabulous caravan memories.

We look forward to “seeing you down the road” at an Ontario event!

Neil and Nancy M.



Waiting for Parade - “Living the Dream” Salem, 2018

Editorial

Steve A.

Airstream misadventure #17

Spring of 2018, our second season of Airstream travel. We'd just collected our rig from winter storage at Can-Am. On the way back home, we did an overnight at Green Acre Park in Waterloo. We parked, hooked up and looked forward to our first night's camping of the season. I was outside and Karen called through window "There's a burbling sound coming from the bathroom sink!" I went inside and sure enough, there was not only a burbling sound, but water quickly filling, and ultimately overflowing the sink! My first instinct was to shut everything off. I ran outside, turned off the water, and checked that sewer valves were closed.

Back inside. The flooding had stopped and we desperately tried to contain the water before it escaped under the cabinetry. After the panic, I paused to figure out where the water came from. A) Both tanks were empty as we'd just taken the rig out of storage. B) There's no connection from the water hookup to the black tank (right?). So what the heck? I decided to try an experiment and asked Karen to watch the sink while I turned the water back on. After one twist of the faucet she screamed "Turn it off! Turn it off!" Another spill to mop up.

Well, I was flummoxed. It was a few minutes before Can-Am closed for the day so I quickly gave them a call. The tech I talked to was likewise flummoxed. He said "Let me go talk to Andy." I waited. A few minutes later he came back and said "Apparently, the bathroom sink in some models is plumbed into the black tank rather than the grey tank. Is it possible that you connected the water hose to the black tank flush inlet rather than the city water inlet?" Sure enough, the hose was connected to the flush inlet right above the warning sign that says not to do that. Feeling like a complete idiot, I thanked the technician profusely and sheepishly moved the hose to its proper place.

We were quite fortunate that the black tank was clean and dry after winterization. Had the tank been less than clean the consequences would have been ... unfortunate.

Lesson learned.

I'd be remiss if I didn't acknowledge Linda S's last submission of the Sunshine Report. Linda has been an absolute rock in my short time as editor, but she's been sowing sunshine since August of 2019. Linda often had the difficult task of relaying the most tragic news but somehow the reader always came away uplifted. Thank you, Linda. Our new Sunshine correspondent has big shoes to fill, but more about that in Linda's article.

Caravan Corner

Kerry M.

Caravans: What's the Big Deal?

Occasionally I see comments posted online asking what is the big deal with caravans? These comments always seem to come from folks who haven't been on one and either have no idea or a misconception of what a caravan really is (and is not). Let's see if we can dispel some myths.

Firstly, a caravan is not a line of RVs traveling nose to tail convoy style and presenting a rolling road block on the highway. Our Airstream caravans are always well spaced out on the road, traveling in groups of no more than three rigs, leaving room between so that traffic moving faster can pass. The old saying is "If you can read the numbers of the trailer ahead, you are too close". We also encourage all drivers to respect the truckers and let them get by, they earn a living by covering miles while we are there for fun.

Second, who wants to travel with a bunch of people that you don't know? Well, it doesn't take long in any caravan to get to know your fellow travelers. Friendships will be born that will last years. You see, a caravan is really a traveling social group of like-minded people from diverse backgrounds sharing common experiences. It's surprising what we can learn from each other.

Third, caravans are too rigid. OK yes, the itinerary is set in advance and activities or attractions are pre-booked. But isn't it nice to know that someone else has taken care of the planning and arrangements? All you need to do is show up and enjoy. Many caravans offer some free time to do your own thing on non-travel days and the chances are pretty good that you will meet a few people in your group who enjoy the same special interests as you. Biking, hiking, whatever floats your boat, it's fun to get out there and share your adventures.

Let's admit it, we all get a good feeling of seeing a bunch of our silver icons gathered at a campground or rest area. There is no doubt that our caravans attract attention and curious folks ask questions. We are all club ambassadors at those times and it's fun to share our lifestyle with interested members of the public. As more of us get out there, we now seldom get the comment "They don't make those things any more ,eh". They sure do and here we are.

There are a host of reasons why caravans are getting ever more popular in our club. Our Meandering the Maritimes Caravan has filled all 20 spaces and has a waiting list with another 30 names on it. Many of the early signers joined simply on the basis of word of mouth. Our best advertising is members relating their own experiences. Just ask anyone who has done any caravan and you will find them happy to share their experiences. Try it, you will be hooked.



New York City Caravan

Sunshine Report

Linda S.

It is with a deep sadness in my heart that this, my last report as Sunshine Chair, begins with the loss of another member of our Club. Linda W. lost her battle with cancer in March, leaving to mourn her beloved husband, Russ. We extend our heartfelt sympathy to Russ, family and friends.

To each one of you who contacted me, I thank you for sharing your memories of Linda. She was a dear friend to so many of us. It was her smile, her laughter and the good will she left with each one that they will cherish. She was loved and she will be remembered.

I am writing my last communication to you and finding it not an easy task after five years of connecting with so many of you. Indeed, the majority of cards were sent to those who were ill or had lost a loved one. But others were sent to lift up a heart who just needed to know we cared about them. Some I wrote with tears and some with joy. It is the nature of this task. I am grateful to have a wonderful successor! Lynn B. spoke to me about taking over about two years ago. When I asked her last fall if she was still interested, she was indeed. Now she will add her greetings to the cards she creates. Our plan is to meet on May 9th, at her home to pass on my records and where John and I will courtesy park to enjoy an evening of catch-up with her and hubby, Bernie. Then it's off to Seaforth for the Western Ontario Shakedown and Blyth for the Spring Rally & AGM.

While we have enjoyed our winter at home this year, it is almost spring and it just feels like it could hurry up a bit. Looking ahead to summer and its varied activities is great but so also is enjoying the handiwork displayed in this photo taken north of Sault Ste. Marie in February.

Finally, I wish you all a sunny summer and look forward to seeing as many of you as possible this season.

Most of all, I thank you for the opportunity to serve the OCAC as Chair of the Sunshine Committee.

Farewell and Bon Voyage!

Linda



My Tank Overfloweth

John R.

Well, spring is here, and you have successfully un-winterized your Airstream, or so you thought, until you connected to city water and notice after several minutes that the freshwater tank is overflowing.

The question here is how is this happening? "This never happened before" is your first thought and how is the city water connection connected to the freshwater tank? To fill the freshwater tank, you need to unlock the little door and put water in the freshwater fill port, but you are connected to the city water connection.

To get water to a tap inside your Airstream you can either use the city water connection or the on-board water pump which takes water from the freshwater tank, so there is a connection between the city water connection and the on-board pump. The connection is at or near the discharge line of the on-board water pump and water is prevented from backflowing into the freshwater tank from the city connection by a non-return valve or check valve that is located inside the on-board water pump. After storage, the internal check valve can get stuck in the open position allowing water from the city water connection to flow backwards through the pump and into the freshwater tank filling it up and then coming out the overflow of the freshwater tank. I had this exact problem after de-winterizing the Airstream last year and the pump was only two years old. I was able to fix the problem by doing the following procedure which does not take very long and will verify if the check valve is stuck or broken.

1. Turn off the city water supply.
2. Turn on the water pump, make sure there is water in the freshwater tank.
3. Run a faucet for 10 to 15 seconds.
4. Turn off the water pump.
5. Turn on the city water supply.
6. Run a faucet for 10 to 15 seconds.
7. Repeat steps 1 to 6 at least 3 more times.

If the problem was a stuck check valve this should, as it did in my case, fix the problem. If not, it indicates a broken check valve. Not all is lost, and you may not need to buy a replacement pump. If the water pump is operating okay, then you have several options.

1. If you are on the road, you can just fill up the freshwater tank and use the on-board pump for your water needs. Then fix the problem at a more convenient time.
2. You could install a check valve in the line of the on-board water pump. Camco has a check valve that fits right on to the water pump (direction of flow marked on valve) This check valve will connect to the suction line and costs around \$20: Camco part # 23303 RV 1/2" backflow preventer. An alternative to this would be a Sharkbite part # 2008-0000LFA 1/2" check valve for about \$40 which can be connected to either the suction or discharge line but requires cutting of the Pex line. Again, direction of flow is marked on the check valve. Amazon carries these as well as your local RV dealer.
3. If you know the make and model of your water pump there are rebuild kits available from Amazon or your local RV dealer for between \$30 and \$50.
4. If the pump is not functioning properly then you will have to replace the pump which will cost between \$120 and \$150.



In my kit of spare parts for the RV I carry an inline check valve in case I have to make a repair while on the road. Now you know why the freshwater tank overflows when connected to city water and what to do. Enjoy the journey!

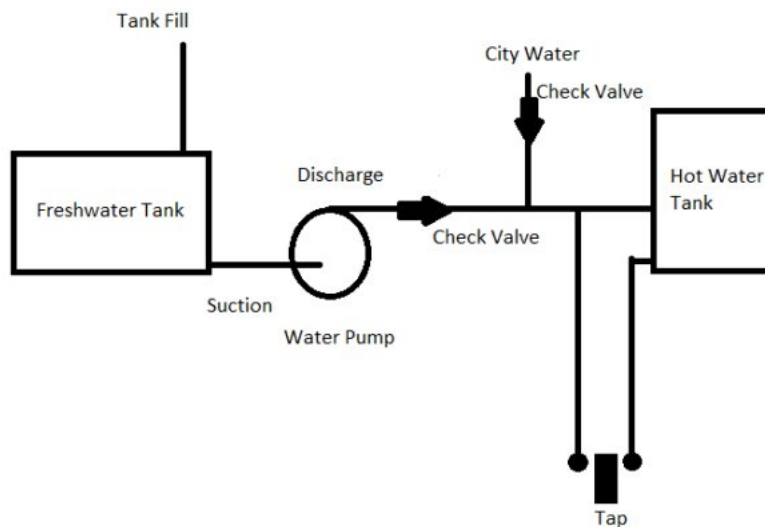

Community Services Update

Project Linus - Joan G.

A Project Linus blanket is underway and the plan is to finish in time for the Blythe rally. Will there be time to make another one with different colours? The challenge is on!

Blankets will be collected at the May Blyth rally.

Our club has such a generous and creative group of "Blanketeers".

Project ♥ Linus



Pop Tabs - Rick A.

[Editor's note: No update from Rick this month, but keep collecting those pop tabs and plastic (not cardboard) bread clips. They will, no doubt, be gratefully accepted at numerous gatherings this year.]