

Air Conditioning System

Heat-Strip

Figure (15) is a schematic for an A-C that includes a heat-strip.

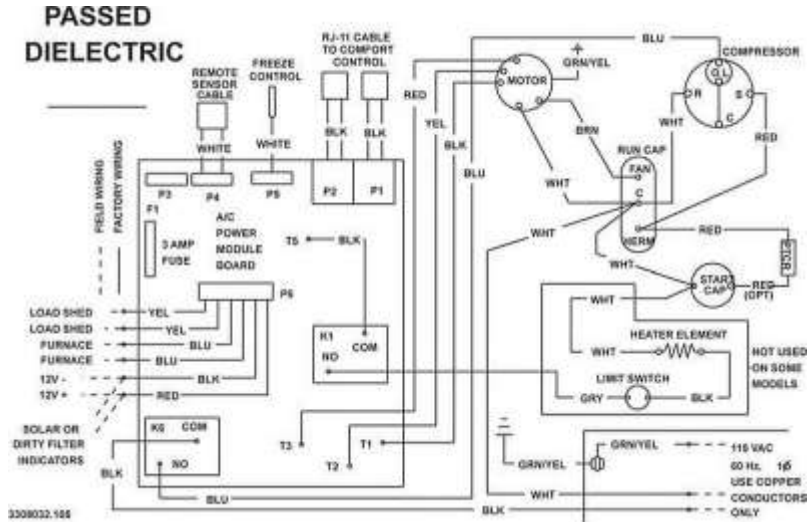

Figure (15) A-C With Heat Strip

The heat strip element is just below the compressor start capacitor on the right. It is turned on and off using relay K1 in the center of the schematic. When you select heat strip on the CCC this will activate the heating element. This is useful for taking the chill off on a cool morning or in the evening when you do not require the furnace. Warmed air will be circulated in the RV. Figure (16) illustrates the actual heat strip which is similar to those used in a portable electric heater.



Figure (16) Heater Strip