

April 2026

NORVA NEWS



What's Inside

- The President's Corner
- Region 3 Rally Recap
- Hot Showers Anyone?
- Upcoming Events
- Other Regional Events

NORVA Executive Officers

President: Jim Oxley

1st VP: Drew Morgan

2nd VP: John Bevis

Secretary: Leslie Stevens

Treasurer: Beverly Bevis

Membership Directors:
Doug and Gail Perkins

Newsletter Editor:
Barbara Formoso

Webmaster: Patsy Nagel

Legislative Director:
Jeff Tlapa

Parliamentarian:
Gerry Nagel

Past President:
Bob Nickel

The President's Corner

It's finally time to bring your campers out of cold storage and get ready for a great next three months!

If you haven't already, please consider joining us at the NORVA Maintenance Rally at Madison Vines RV Resort in Madison, VA, from April 24–26. Currently we have closed the registration for the rally,

but... you can still come. Just call Madison Vines Resort at (540) 948-4186. They will add you to a wait list if a site is not available. If a site does not become available, everyone is still welcome to attend events on Saturday. This is the day of the seminar and a nice opportunity to hang out with all of us. Either way, let Tom know you'll be attending by sending him an email at 2212TJC@gmail.com.



This rally features DJ Mastin, independent Airstream technician and owner of Broken Rivets RV Service, LLC. DJ will host a seminar on the morning of Saturday, April 25, 2026, and will be available throughout the weekend to discuss all aspects of maintaining Airstream trailers and Class B vans. He will also be offering minor repairs and services at a discounted rate.

The RV resort is conveniently located near Charlottesville, making it a great opportunity for a day trip with family members. Madison Vines RV Resort also offers a variety of on-site activities, including optional nightly dinners—just sign up and pay at the front office. For more information, visit: <https://madisonvinesrvresortandcottages.com>

April 2026

Stay in Touch

For all things NORVA:

<https://www.facebook.com/groups/norvairstreamclub>

<https://airstreamclub.org/northern-virginia>

Newsletter contributions, corrections and comments are welcome:

bformoso@me.com

For all things WBCCI:

<https://airstreamclub.org>



“Let’s not make changes, let’s only make improvements.”

Wally Bayam

Next, we kick off the camping season May 1–3 with the NORVA 2026 Chickahominy Riverfront Park Rally in the Williamsburg, VA area, hosted by our Vice President Drew and his wife, Elizabeth Morgan. This marks NORVA’s second rally at this beautiful location.

The campground is ideally situated near the Virginia Capital Trail and offers easy access to Colonial Williamsburg, Jamestown Settlement, Busch Gardens, as well as numerous restaurants, wineries, breweries, and historic sites.

Registration closes May 1. To attend, you must complete two steps

Call the campground at (757) 258-5020 to make your reservation

Register online at: <https://airstreamclub.org/norva-2026-chickahominy-riverfront-park-rally>

Rounding out the next three months is our annual River Rally, June 5–7, hosted by Membership Co-Chairs Doug & Gail Perkins, along with former President Bob and Wendy Nickel.

I’ve been attending this rally since its inception, and it continues to be a fantastic, family-friendly event. This year’s rally will be held at Spacious Skies Shenandoah Views Campground. For details and to sign up, here is the link to registration:

There you have it—a great lineup to start the season. Let’s get streaming, break out the campfires, and enjoy some good old Airstream tradition!

Jim

The Region 3 Rally

This year’s Region 3 rally, with its unique setting in Lakeland, was a great success. We camped between airplane hangars and the airfield at the Sun N’Fun Aerospace Expo Center. The facility is “a nonprofit organization in Lakeland, Florida dedicated to the promotion of aviation education. It is best known for the annual week-long fly-in and airshow at Lakeland Linder International Airport in Lakeland.” An aerospace museum is also located in



April 2026

the complex and vintage aircraft are displayed all over the grounds. We watched small planes take off and land throughout the days and evenings of the rally.



The opening ceremony had all the pomp and circumstance that we are used to at UCI rallies. It's always a treat to see the flags of the clubs, in this case all the clubs and inter-clubs of Region 3. Jim represented NORVA proudly with his inimitable style. We were warmly welcomed by Bob Ealy. He was followed by a presentation by Medical Volunteers of Polk County who run a free clinic for folks in need there. Charity donations were encouraged. Finally we heard from the management of the Aerospace Center for Excellence who described their educational programs. Such an interesting institution encouraging young people to learn about aerospace and prepare for opportunities in the field.



On Friday afternoon there was a fascinating presentation by NOAA including talks by hurricane hunters. A vintage pilot brought his bi-plane, displayed it in the presentation space, told tales of his flying adventures and took off on the airstrip facing our trailers. It was a very special moment.



We were fed well at a couple of all-rally meals, the highlight of which was a pig roast with all the fixings. There was a terrific band that night and a somebody spotted a couple of dancing fools.



NORVA was well represented by the Gerry and Patsy Nagel, Drew and Elizabeth Morgan, Joe and Barb Formoso, John and Bev Bevis, Ron and Leslie Stevens, Tom Carmichael, Jim Oxley, Amanda Zbinden and Beth Keller.

April 2026

Hot Shower In An Airstream... How Is That Even Possible???

“From Polar Plunge to Perfect Temp: Airstream Showers and the Anti-Scald Evolution”

by Ron Stevens

There are few pleasures in Airstream life quite like a good, hot shower after a long day on the road—unless, of course, your “hot” shower feels more like a brisk mountain stream. If you’ve ever stood there shivering and negotiating with the faucet like it’s a stubborn mule, you’re not alone. The culprit is often the well-meaning—but occasionally overprotective—anti-scald valve.

Now, before we blame the hardware, it’s worth appreciating that anti-scald technology is actually a relatively modern luxury. In the broader plumbing world, pressure-balanced anti-scald valves didn’t become common until the late 20th century, gaining traction in the 1970s–1990s as safety standards improved and manufacturers sought to prevent sudden temperature spikes.

Airstream followed a similar path—though, as with many things Airstream, the evolution came with a bit of variation depending on model and era.

If you’re traveling in a **newer Airstream (roughly mid-2000s to present)**—think models like the Flying Cloud, International, Globetrotter, or newer Basecamp, Classic, and Atlas—you almost certainly have a **modern mixing valve with an adjustable anti-scald limiter**. Today’s owner manuals and systems assume these safety features are standard parts of the plumbing setup, designed to keep temperatures stable and safe.

If your Airstream hails from the **1990s to early 2000s**, you’re in a bit of a transition zone. Some units began incorporating pressure-balanced or single-handle mixing valves, but implementation wasn’t always universal. You may have the limiter—or you may have a more basic valve that relies on manual mixing (and a bit of courage).

And if you’re the proud steward of a **vintage Airstream (pre-1990s)**, odds are your shower system is delightfully simple—and completely unapologetic. These earlier rigs typically lacked true anti-scald protection, meaning temperature control was entirely in your hands... and sometimes at the mercy of campground water pressure. One minute you’re enjoying a warm rinse, the next you’re starring in your own survival documentary.

Which brings us back to today—and that slightly-too-cool shower.



April 2026

Most modern Airstream showers include a small but mighty feature: a **temperature limiter hidden behind the handle**. It's usually a plastic ring or stop that prevents you from turning the knob too far toward "hot." With a screwdriver, a little curiosity, and maybe a dash of bravery, you can remove the handle and nudge that limiter a notch or two warmer.

Think of it as politely telling your Airstream, "I appreciate your concern... but I've got this."

Of course, moderation is key. The goal isn't to turn your aluminum sanctuary into a rolling lobster pot. Make small adjustments, test the water, and find that perfect balance between comfort and safety—especially if others are using the trailer.

In the end, the anti-scald valve is just another example of how Airstreams have evolved: blending timeless design with modern convenience. Whether you're dialing in a 2025 Classic or mastering the quirks of a 1970s Sovereign, there's a certain joy in making these small tweaks that make life on the road just a little better.

So here's to warmer showers, fewer goosebumps, and the quiet satisfaction of outsmarting a very polite piece of plumbing.

And...here's how you do it:

1. Remove the handle from the faucet. On our Classic, the Kohler handle can be removed without tools by simply unscrewing the conical trim ring – Kohler calls this a mud guard – behind the faucet handle. No tools...just grab with your hand and turn.
2. The conical trim ring and handle will come off at this point revealing a slotted brass sleeve (valve stem) that engages the handle.
3. Remove the brass sleeve using a small Phillips screwdriver.
4. Turn on the water supply. Turn the valve stem clockwise to the full hot position. You'll notice that the valve stem will only rotate so far until it hits the stop limit. This stop limit is what we're going to be adjusting.

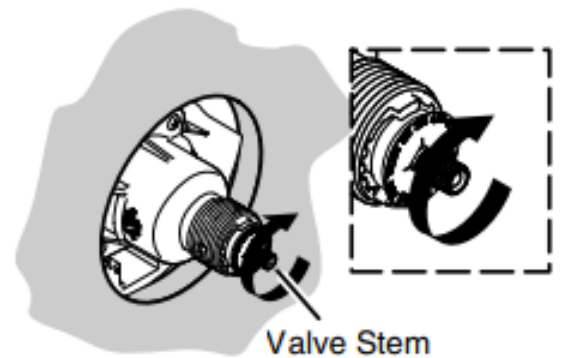

April 2026

5. Measure the maximum water temperature. If the water is too hot or cold, adjustment is required.

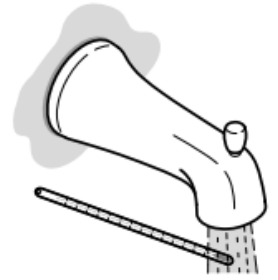

6. Next, pull off the temperature stop limiter and reinsert it so that it will allow the handle to rotate more clockwise (to make it hotter) or anti-clockwise (to make it colder).

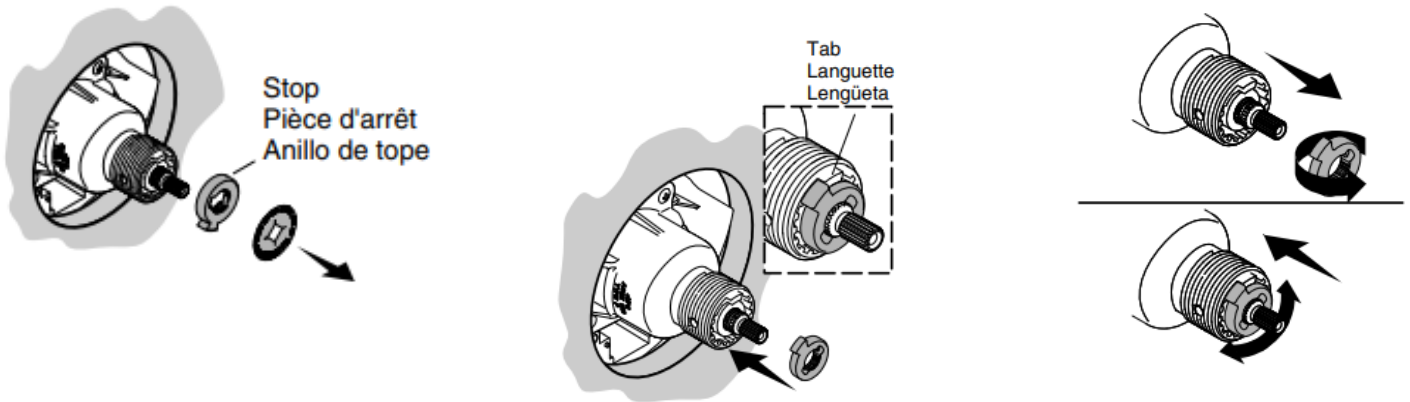

7. Once you're happy with the temperature, reinstall the slotted brass valve stem and handle assembly.
8. Done! Enjoy hot water in your Airstream!



April 2026

The rally fee is \$20.00 per adult person. You will pay your rally fee when you arrive at the rally and will receive a folder of local hikes, entertainment, and interests.

Below are some of the activities planned for the River Rally:

- Friday –Happy hour, Pizza (provided) and Bingo (fun prizes)
- Saturday – Dog playtime, Wine tasting/pot luck dinner, Corn hole tournament
- Sunday – Pancake breakfast (provided), and Rafting trip.

The rafting trip is through an Outfitter Company. We will obtain their fees at a later date, which you will pay separately. It's a gentle part of the river, about 4-5 people to a raft, and just a fun time to float down the river and enjoy the scenic beauty.

If you have any questions, please feel free to contact Doug or Gail Perkins, or Bob or Wendy Nickel.

Our next big club event is our caravan to the **International Rally in Minot, ND**, hosted by John and Beverly Bevis. Register here:
<https://airstreamclub.org/norva-north-minot-2026-caravan-lc-2026-2>

Here is their description of this year's annual trip to International:

The caravan start date is **Friday, August 7, 2026** at PennWood Airstream Park in New Bethlehem, PA where we will have an informal get acquainted dinner and initial meeting. We spend two nights at this location.

On Sunday, August 9, 2026 we travel to and camp at Maumee Bay State Park near Toledo, OH for two nights. On August 10th, activities include a visit to the Toledo waterfront where we will visit The National Museum of the Great Lakes. A docent guided tour of the ships on exhibit is planned. On Tuesday, August 11, 2026 we travel into Michigan where we have an overnight stay at Bay City State Recreation Area located on Saginaw Bay and Lake Ontario.

On Wednesday, August 12, 2026 we travel to the Upper Peninsula. We will spend three nights at Lakeshore RV Park, St. Ignace, MI. A dinner in the campground pavilion is planned. The main attraction is a ferry ride and day trip to Mackinac Island. A free day is scheduled. You can relax or suggested excursions include the St. Ignace waterfront, shops, local market or travel about one hour north to the famous Soo Locks and visitor center.

On Saturday, August 15, 2026 we travel to Bewabic State Park, Crystal Falls, MI for one overnight stay.

On Sunday, August 16, 2026 we travel to Indian Point Campground in Duluth, MN where we stay for two nights. A group dinner is planned and a day trip to the Duluth Aerial Lift Bridge and Museum is planned for August 17th.



April 2026

On Tuesday, August 18, 2026 we travel to East Grand Forks, MN where we spend two nights at Red River State Recreation Area Campground. A guided nature tour, possibly by canoe, or hiking the abundant trails is planned. This location offers several naturalist activities. A group dinner is planned for Wednesday, August 19, 2026.

On Thursday, August 20, 2026 we travel to Minot, ND where we will spend one night at Valley View RV Park. This is the final stop for the caravan.

Please note most campgrounds are full hook-up. Some campsites have electric, water and dump stations. Full details will be provided to participants.

Currently a rough kitty fee estimate is \$1750 to \$1800 per unit, which includes all camping, planned meals and tours. The estimate is for two people per trailer so singles will be less. Once we have a final number of commitments, I will be able to get a more precise cost to everyone.

If you interested in participating in the North to Minot 2026 Caravan LC-2026-2, complete the registration at the link above and submit \$500 deposit via check to John Bevis, 205 McHenry Street, SE, Vienna, VA 22180.

Other Regional Events



For tons of other events with other clubs in our region, click here:

<https://airstreamclub.org/events?from=&to=&type=736&state=-1&club=-1>

April 2026

**Airstream of Virginia:
5921 Mallard Road
Woodford, VA 22580**

Blue Compass RV
has a brand new Airstream location!



AIRSTREAM
OF VIRGINIA

